

# MAT14CS

MAYTAG® COMMERCIAL  
ENERGY ADVANTAGE™  
TOP-LOAD WASHER



## LEGENDARY MAYTAG DEPENDABILITY

Maximizing your equipment investment for over a half century.



### FOR YOUR CUSTOMERS:

- Proven Cleaning Performance
- Extra-Large Lid And Tub Opening
- Dial-A-Fabric™ Cycle Selection
- Cycle Stage Indicator Lights
- Easy-To-Operate Coin Slide

### FOR YOUR OPERATION:

- The Most-Efficient, Best-Cleaning Top-Load Washer From Maytag
- Front Access For Easier Self Service
- Accepts A Variety Of Slides

### BUILT-TO-LAST™ FEATURES:

- Premium Porcelain-Enamel Top
- Beltless Design
- Dependable Direct Drive Transmission
- Self Cleaning Pump
- High Security Vault
- Reliable Electro-Mechanical Controls
- Best Warranty In The Business



LAUNDRY SOLUTIONS  
YOU CAN *DEPEND* ON.

REDUCES WATER USAGE **BY 25%\***

visit [maytagcommerciallaundry.com](http://maytagcommerciallaundry.com)  
or call 800-662-3587

\* Compared to Maytag® top-load washers manufactured before 2005.



## OUR COMMITMENT TO DEPENDABLE QUALITY

At Maytag, we believe durable goods should remain just that. That's why every Maytag® product is constructed of the highest-quality materials and with the utmost in precision craftsmanship. It's also why we stand behind our equipment with solid service and support from our professional Maytag laundry suppliers. Simply put, when you choose Maytag® products, you ensure your peace of mind.



## MAT14CS

MAYTAG® COMMERCIAL ENERGY ADVANTAGE™ TOP-LOAD WASHER

## Maytag® Commercial Energy Advantage™ Top-Load Washer

### MECHANICAL COIN SLIDE-READY

WASHER SPECIFICATIONS	
<b>MODEL</b>	<b>MAT14CS</b>
<b>MOTOR</b>	
Single-phase, reversible, thermoprotected, high torque	•
HP (kw)	½ (.37)
<b>APPROXIMATE WATER USAGE</b> — gallons (liters)	
Average hot water usage per cycle	3.2 (12.1)*
Average total water usage per cycle	23.2 (87.8)*
<b>ELECTRICAL RATING</b>	
Domestic model — voltage	120V/60 Hz
Export model — voltage	220-240V/50 Hz
<b>BREAKER/FUSE REQUIREMENT</b>	
Domestic model — amps	15
Export model — amps	10
<b>CYLINDER</b>	
Volume — cu. ft. (liters)	2.5 (70.8)
Diameter — in. (mm)	18.4 (468)
Depth — in. (mm)	17.8 (454)
<b>LID OPENING</b>	
In. (mm)	18 (457)
<b>EXTRACT SPEED</b>	
Maximum rpm	640
Maximum g-force	107
<b>OPERATING PRESSURE</b>	
Psi (bar)	20-100 (1-8)
<b>INLET HOSE LENGTH</b>	
Ft. (m)	4.5 (1.37)
<b>DRAIN HOSE LENGTH</b>	
Ft. (m)	4.4 (1.34)
<b>APPROXIMATE WEIGHT</b>	
Crated — lbs. (kg)	178 (80.7)
Uncrated — lbs. (kg)	164 (74.4)

\* Average based on JI testing with factory preset cycles.  
See specific instructions for proper installation. Because of continuous product improvement, Maytag reserves the right to change specifications without notice.

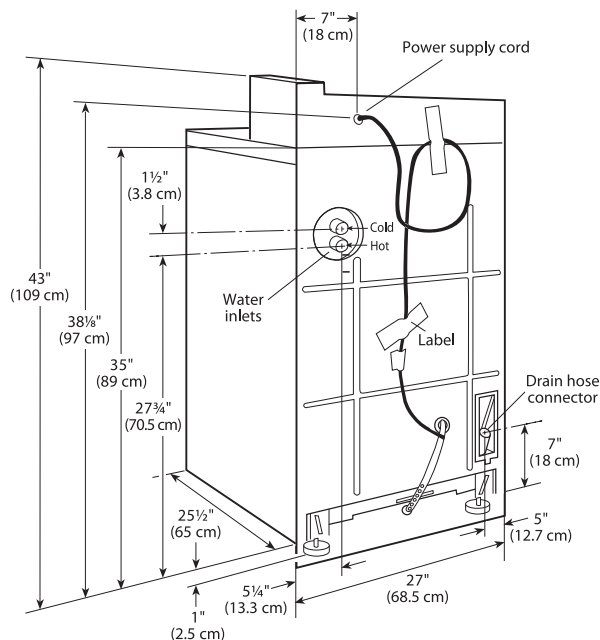

NEW YORK CITY M.E.J.A.



## THE BEST WARRANTY IN THE BUSINESS— 5 YEARS ON ALL PARTS

For a period from the date of original purchase through the time listed above, the designated parts that fail in normal commercial use will be repaired or replaced free of charge for the part itself, with the owner paying all other costs, including labor, transportation and customs duty. Chemical damage is excluded from all warranty coverage. See complete warranty for details.